

"Vanguard" Hand Cutting Torches



Specifications and Ordering Information

ST2600 "Vanguard" Series - For use with any fuel gas. Uses Series 1 cutting tips

- Cuts 1/8"/3.25mm to 16"/400mm

Includes Built-in patented flashback arrestors and reverse flow check valves for added safety



ST 2600FC

ST2600 "VANGUARD" SERIES ORDERING INFORMATION

Part Number	Model Number	Lever Position	Tip Series	Head Angle	Length
0381-1486	SST2600FC	Top Rear	1	90°	17"/43cm
0381-1480	ST2600FC	Top Rear	1	90°	21"/53cm
0381-1481	ST2600FCL	Top Rear Locking	1	90°	21"/53cm
0381-1485	ST2602FCL	Top Rear Locking	1	180°	21"/53cm
0381-1490	ST2610FC	Top Rear	1	90°	27"/68cm
0381-1493	ST2612FC	Top Rear	1	180°	27"/68cm
0381-1496	ST2630FC	Top Rear	1	90°	36"/91cm
0381-1497	ST2630FCL	Top Rear Locking	1	90°	36"/91cm
0381-1501	ST2632FCL	Top Rear Locking	1	180°	36"/91cm
0381-1505	ST2661FCL	Top Rear Locking	1	75°	60"/1.52m
0381-1506	ST2670FCL	Top Rear Locking	1	90°	72"/1.83m
0381-1507	ST2670FCL	Top Rear Locking	1	90°	72"/1.83m
0381-1512	ST2690FCL	Top Rear Locking	1	90°	96"/2.44m

Note: Other torch models available. Ask for details.



Hand Cutting Torches

Specifications and Ordering Information



ST900FC

ST900FC "Vanguard" Series - For use with any fuel gas 5 PSIG and above. Use with Series 1 Cutting Tips. Cuts 1/8"/3.25mm to 6"/150mm. Hose connections are 9/16"-18' unless noted.

Includes built-in patented flashback arrestors and reverse flow check valves for added safety.

ST900FC "VANGUARD" SERIES ORDERING INFORMATION

Part Number	Model Number	Lever Position	Tip Series	Head Angle	Length
0381-1620	SST900FC	Top Rear	1	90°	17"/43cm
0381-1622	SST901FC	Top Rear	1	75°	17"/43cm
0381-1621	SST900FC	Top Rear	1	90°	21"/53cm
0381-1623	ST901FC	Top Rear	1	75°	21"/53cm
0381-1627	ST910FC	Top Rear	1	90°	27"/69cm
0381-1628	ST912FC	Top Rear	1	180°	27"/69cm
0381-1624	ST930FC	Top Rear	1	90°	36"/91cm



ST1000FC

ST1000FC "VANGUARD" SERIES ORDERING INFORMATION

Part Number	Model Number	Lever Position	Tip Series	Head Angle	Length
0381-1640	SST1000FC	Bottom Rear	1	90°	17"/43cm
0381-1641	ST1000FC	Bottom Rear	1	90°	21"/53cm
0381-1642	SST1001FC	Bottom Rear	1	75°	17"/43cm
0381-1643	ST1001FC	Bottom Rear	1	75°	21"/53cm
0381-1644	ST1030FC	Bottom Rear	1	90°	36"/91cm
0381-1645	ST1031FC	Bottom Rear	1	75°	36"/91cm
0381-1646	ST1032FC	Bottom Rear	1	180°	36"/91cm

Note: Other models available. Ask for details.

*3 seat acetylene and LPG fuel gas cutting tips are available.

See **Meco** gas apparatus section.

Standard Hand Cutting Torches



Specifications and ordering information

ST1600C / 1700C / 1800C / 1900C Series - For use with any fuel gas. Cutting capacity 1/8"/3.25mm to 16"/400mm.

- Integral patented reverse flow check valves for additional safety



ST1600C



ST1700C



ST1800C



ST1900C

ST1600C SERIES ORDERING INFORMATION

Part Number	Model Number	Lever Position	Tip Series	Head Angle	Length
0381-0527	SST1600C	Top Rear	1	90°	17"/43cm
0381-0520	ST1600C	Top Rear	1	90°	21"/53cm
0381-0532	ST1610C	Top Rear	1	90°	27"/68cm
0381-0575	ST1630C	Top Rear	1	90°	36"/91cm
0381-0591	ST1650C	Top Rear	1	90°	48"/122cm
0381-0607	ST1670C	Top Rear	1	90°	72"/1.83m
0381-0547	SST1700C	Bottom Rear	1	90°	17"/43cm
0381-0540	ST1700C	Bottom Rear	1	90°	21"/53cm
0381-0543	ST1710C	Bottom Rear	1	90°	27"/68cm
0381-0638	ST1730C	Bottom Rear	1	90°	36"/91cm
0381-0654	ST1750C	Bottom Rear	1	90°	48"/122cm
0381-0664	ST1762C	Bottom Rear	1	90°	60"/1.52m
0381-0700	SST1800C	Top Front	1	90°	17"/43cm
0381-0678	ST1800C	Top Front	1	90°	21"/53cm
0381-0679	ST1801C	Top Front	1	75°	21"/53cm
0381-0681	ST1810C	Top Front	1	90°	27"/68cm
0381-0699	SST1900C	Bottom Front	1	90°	17"/43cm
0381-0687	ST1900C	Bottom Front	1	90°	21"/53cm
0381-0722	ST1900CT	Bottom Front 'Trigger'	1	90°	21"/53cm
0381-0721	ST1901CT	Bottom Front 'Trigger'	1	75°	21"/53cm

Note: Other torch models available. Ask for details.

VICTOR® Hand Cutting Torches

Specifications and Ordering Information

ST900C Series - For use with any fuel gas 5 PSIG and above. Use with Series 1 Cutting Tips. Cuts 1/8"/3.25mm to 6"/150mm. Hose connections 9/16"-18m unless noted. Equipped with patented built-in check valves for added operator safety. Integral patented reverse flow check valves for additional safety.



ST900C

ST900C SERIES ORDERING INFORMATION

Part Number	Model Number	Lever Position	Tip Series	Head Angle	Length
0381-0486	SST900C	Top Rear	1	90°	17"/43cm
0381-0488	SST901C	Top Rear	1	75°	17"/43cm
0381-0487	ST900C	Top Rear	1	90°	21"/53cm
0381-0489	ST901C	Top Rear	1	75°	21"/53c
0381-0490	ST910C	Top Rear	1	90°	27"/69cm
0381-0492	ST912C	Top Rear	1	180°	27"/69cm
0381-0494	ST931C	Top Rear	1	75°	36"/91cm

Specifications and Ordering Information



STN4700C

The STN 4700C can be used on fuel gases, other than acetylene, at pressures as low as two ounces. ST 4700C uses a Venturi mixer that creates a siphoning action for the fuel gas from the pre-heat oxygen flow. All STN 4700C torches are equipped with patented built-in check valves for added operator safety. Hose connections are 9/16"-18m.

- Cutting capacity - 1/8"/.32cm to 12"/30cm

STN4700C SERIES ORDERING INFORMATION

Part Number	Model Number	Lever Position	Tip Series	Head Angle	Length
0381-1400	SSTN 4700C	Bottom Rear	See Note	90°	17"/43cm
0381-1410	SSTN 4700C	Bottom Rear	See Note	90°	21"/53cm
0381-1430	SSTN 4730C	Bottom Rear	See Note	90°	36"/91cm

Note: ST4700 torches may be used with any **Victor** series 1 cutting tip designed for fuel gases other than acetylene. Other STN 4700 torch models available. Ask for details.



CST800C

CST800C Series - For use with any fuel gas 2 PSIG and above. Use with Series 3 Cutting Tips. Hose connections are 9/16"-18m.

- Cutting capacity - 1/8"/3.25mm to 6"/150mm

CST800C torches are equipped with patented built-in check valves for added operator safety.

CST800C SERIES ORDERING INFORMATION

Part Number	Model Number	Lever Position	Tip Series	Head Angle	Length
0381-0441	CST800C	Top Front	3	90°	17"/43cm

Note: Other models available. Ask for details.

Specifications and Ordering information

Victor machine cutting torches are available in two and three hose models. High performance “straight through” design minimizes turbulence and improves cut quality. Accessory reverse flow check valves are supplied for use at torches inlet connection. All machine torches use series 1 cutting tips.



MT5 SERIES

MT-5 SERIES - 3 HOSE TORCHES ORDERING INFORMATION

Part Number	Model Number	Total Length	Barrel Length	Racking Length	Gas
0380-0208	MT-5	8 1/2"/214mm	5 3/8"/135mm*	5 3/8"/135mm	Any
0380-0209	MTN-5	8 1/2"/214mm	5 3/8"/135mm*	5 3/8"/135mm	LP/NG

* Barrel Diameter 1 3/8"/34.9250

mm



MT200 SERIES

MT-200 SERIES - 2 HOSE TORCHES ORDERING INFORMATION

Part Number	Model Number	Total Length	Barrel Length	Racking Length	Gas
0380-0217	MT210A	14"/355mm	10"/252mm	7"/176mm	ACET*
0380-0216	MT210N	14"/355mm	10"/252mm	7"/176mm	LP/NG**
0380-0219	MT218A	22"/560mm	18"/460mm	15"/375mm	ACET*

MT-300 SERIES - 3-HOSE TORCHES ORDERING INFORMATION

Part Number	Model Number	Total Length	Barrel Length	Racking Length	Gas
0380-0222	MT310A	14"/355mm	10"/252mm	7"/180mm	ACET*
0380-0220	MT310N	14"/355mm	10"/252mm	7"/180mm	LP/NG**
0380-0221	MT310NV	14"/355mm	10"/252mm	7"/180mm	ACET*
0380-0223	MT310AV	14"/355mm	10"/252mm	7"/180mm	ACET*
0380-0227	MT318A	22 1/2"/585mm	18"/460mm	15"/375mm	ACET*
0380-0228	MT318AV	22 1/2"/585mm	18"/460mm	15"/375mm	ACET*
0380-0225	MT318N	22 1/2"/585mm	18"/460mm	15"/375mm	LP/NG**

May also be used on other pressurized fuel gasses
 **May also be used on other fuel gases except acetylene

Other machine torch models available. Ask for details.
Gear racks (24 pitch or 32 pitch) must be ordered separately!



MT300 SERIES

Mill and Foundry Cutting Torches



Specifications and Ordering Information

Precision engineered for steel mill, scrap yard, foundry, and other severe duty applications



HC1400 (Two hose), HC1500 (Three hose) Scrap Torches - For use with Butane, Propane, Natural Gas. Uses Series 2-285N Cutting Tips.

HC1400/1500 SERIES ORDERING INFORMATION

Part Number	Model Number	Head Angle	Hose Conn. Cutting Oxy	Hose Conn. Pre-heat Gases	Length
0381-0770	HC1410	180°	7/8"-14(RH)	9/16"-18 LH/RH	27"/68cm
0381-0773	HC1430	180°	7/8"-14(RH)	9/16"-18 LH/RH	36"/91cm
0381-0776	HC1450	180°	7/8"-14(RH)	9/16"-18 LH/RH	48"/121cm
0381-0782	HC1460	180°	7/8"-14(RH)	9/16"-18 LH/RH	60"/1.5m
0381-0779	HC1470	180°	7/8"-14(RH)	9/16"-18 LH/RH	72"/1.8m
0381-0785	HC1490	180°	7/8"-14(RH)	9/16"-18 LH/RH	96"/2.4m
0381-0790	HC1400	180°	7/8"-14(RH)	9/16"-18 LH/RH	144"/3.6m
0381-0444	HC1500	180°	7/8"-14(RH)	9/16"-18 LH/RH	56 1/2"/1.4m



SCT3000 Series Scarfing Torch - For use with Natural Gas and Propane. Uses Series 1-300N Cutting Tips.

SCT3000 SERIES ORDERING INFORMATION

Part Number	Model Number	Heat Angle	Hose Conn. Cutting Oxy	Hose Conn. Pre-heat Gases	Length
0381-0776	SCT3048	75°	7/8"-14(RH)	9/16"-18 RH/LH	48"/121cm

Note: Other models available. Ask for details.

VICTOR® VCM-200 Cutting Machine

Specifications and Ordering information

VCM-200 Portable Cutting Machine

The versatile VCM-200 is a precision, tractor-type machine that can be used on its own track for straight line cutting and a variety of welding operations. Off track and with a radius rod assembly, the VCM-200 can be used for circle cutting.

VCM-200 Features

- Large thumb screws for hand tight adjustments.
- Dual drive controls & direct speed readout.
- Cone disc drive.
- Constant speed AC induction motor located on the side opposite the torch for cooler, more efficient operation.
- Counter-balanced design allows torch racking distance up to 18" from the machine.
- Speed constant over wide range of temperatures.
- Torch holder designed for 1-3/8"/35mm barrel diameter torches.

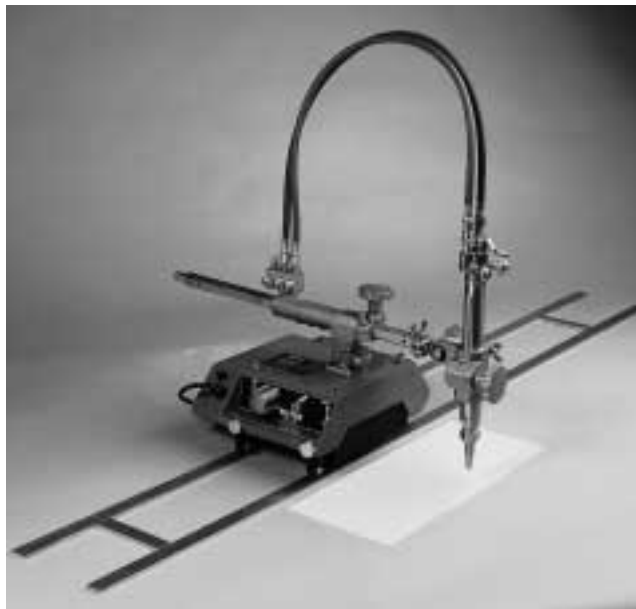

Specifications

Cutting Capacities

- Length increments of 72"/1.83m (Track length)
- Circle diameters 4"/100mm to 96"/2.44m

Speed Range

- 1"/25.2mm to 60"/1.52m/Minute

Dimensions

- Length - 14.25"/359mm
- Width - 11"/277mm (Machine Only)
28.5"/718mm (Machine & Torch Holder)
- Height - 11.5"/289mm (Top of Torch Holder)
5.5"/138mm (Top of machine)

Weight

- Machine - 47.0 lbs./21kg

VCM-200 HS (High Speed)

The VCM-200HS has all the convenience and portability features of the standard VCM-200 machine, plus a speed range of 5"/13cm to 120"/305cm / Minute. The VCM-200HS has a flat mounting deck.

VCM200 SERIES ORDERING INFORMATION

VCM-200 Part NO.	VCM-200HS Part NO.	VCM-200HT Part NO.	Model/Number Description
0200-0220	0200-0224	0200-0240 *Includes Heat Shield	VCM-200, VCM-200HS, VCM-200HT Includes machine, MT 210A torch, rack, 1-1-101 cutting tip, hoses and fittings for 2-hose operation, 32 pitch pinion torch holder, 3-hose manifold block.
0200-0221	0200-0225	0200-0241 *Includes Heat Shield	VCM-201, VCM-201HS, VCM-201HT Includes machine, 32 pitch pinion torch holder, 3-hose manifold block and hoses & fittings for 2-hose operation.
		0200-0242	VCM-202HT Machine w/Heat Shield

ACCESSORY ORDERING INFORMATION

Part Number	Description
0212-0018	12 foot track section for line cutting
0212-0005	6 foot track section for line cutting
0252-0040	Radius rod for circle cutting
0253-0042	100 inch radius rod for circle cutting
0252-0136	Dual torch mount assembly
0252-0103	Heat Shield

DC 2400 Duplicutter



Specifications and Ordering information

DC 2400 Portable Shape Cutting Machine

The mobility and portability of the DC 2400 makes it well suited for both in-plant and on-the-job site applications. Stable, rigid construction allows smooth cuts and production tolerances can be held to 1/16"/1.6mm

Features

- Fully adjustable legs for positive positioning
- Rigid post-assembly assures accurate alignment of torch.
- Heavy-duty, direct current motor and solid state controls provide optimum speed regulation.
- Adjustable template arm assembly.
- Torch holder with 32 pitch pinion.
- Portable, fold-up construction

Specifications

Standard Speed Range

- 1/4" (6.4mm) Rotor; 1.5 to 35 Inches/Minute (38mm to 889 mm/min)
- 1/2" (12.8mm) Rotor: 3.0 to 70 Inches/Minute (76mm to 1778 mm/min)

Cutting Capacity

- Up to 7"/179mm
- Circle diameter 1/4"/.64cm to 19-1/2"/50cm
- Rectangles up to 12"/30cm x 35"/89cm

Dimensions

- Width - 30"/76cm
- Height - 34-3/4"/88cm
- Depth - 33"/84cm

Weight

- Weight - 80 lbs./36kg



DC 2400 DUPLICUTTER ORDERING INFORMATION

DC 2400 Part Number	DC2400E Part Number	Description
0200-0079	0200-0102	DC 2400, DC 2400E Includes MT 210A torch, 1-1-101 cutting tip, hoses & fittings for two hose operation.
0200-0080	0200-0102	DC 2400A, DC 2400AE Includes machine only.

Note: "E" denotes Export Models. Includes 220V to 110V stepdown transformer. Standard Machine is 110V

VICTOR® MHT-100 Motorized Hand Torch

Specifications and Ordering information

Precision

Cutting Simplified

The MHT-100 is an advanced motor-driven, hand held cutting torch that is ideal for cutting operations where a machine-quality cut is desired or essential. Precision accuracy and results are possible each time the MHT-100 is used, even if the operator has limited experience. The MHT-100 can be used with any fuel gas and all attachments are stainless steel.

Features:

- Cuts straight lines, bevels, contours and circles on material from 1/16"/.16cm to 2-1/2"/6.4cm thick.
- The drive wheel assembly rotates 360 degrees.
- "Universal" gas mixer provides optimum gas mixing
- Unique cam-lock brake lever permits quick drive wheel positioning.
- 3-Position control switch with forward, reverse and off positions.
- Built-in check valves for added safety.
- Cutting oxygen lever has lock-open feature.
- Patented drive mechanism is closed and protected.
- TEFLON® coated wiring harness for higher temperature tolerances.
- Optional 12 volt portable battery pack for up to 20 hours per charge.

Specifications:

- Operates on 12 volt DC current
- Power may be provided through standard 110V outlets, a 12 volt auto battery or Victors optional MHT battery pack.
- Variable speed control permitting travel speeds from 4"/11cm to 36"/91cm/minute.
- Regulated power supply will operate on 50/60 hertz single phase from 105 to 130 volts AC, without affecting speed.
- Two circle cutting attachments range from 1"/2.54cm to 5"/13cm and optional 5"/13cm to 24"/64cm diameter.









MHT-100 KIT ORDERING INFORMATION

Part Number	Description
0200-0210	MHT-100: Drive wheel assembly, small circle cutting attachment, battery clip assembly, transformer

Export models available. Ask for details.

VICTOR® One Piece Acetylene Cutting Tips

CUTTING TIP ORDERING INFORMATION

Description	Illustration	Style/ Model	Size	Part Number
General Purpose hand & machine torch cutting. Series 1				0 0330-0298
				1 0330-0299
				2 0330-0300
				3-100 0 0330-0005
				1 0330-0006
				2 0330-0007
Series 3				
General Purpose hand & machine torch cutting. Series 1				000 0330-0003
				00 0330-0004
				0 0330-0012
				1 0330-0005
				2 0330-0006
				3 0330-0002
				4 0330-0007
				5 0330-0008
				6 0330-0009
				7 0330-0013
8 0330-0014				
General Purpose hand & machine torch cutting. Series 3				000 0331-0002
				00 0331-0009
				0 0331-0013
				1 0331-0014
				2 0331-0015
				3 0331-0016
				4 0331-0017
				5 0331-0018
6 0331-0019				
General Purpose hand cutting. Machine cutting 30° with torch perpendicular. (Series 1)				1 0330-0198
				0330-0199
				0330-0284
General Purpose extra length tips. Series 1				00 0330-0654
				0 0330-0566
				1 0330-0567
				2 0330-0655
				3 0330-0656
				4 0330-0531
				6 0330-0535
Heavy cutting with hand or machine torch. For best results use MT 300A series machine torch (Series 1)				1-104 8 0330-0048
				10 0330-0053
Boiler tube removal. Tip is short to insert head & tip inside tube, or in confined area. Series 1				1-108 0 0330-0058
				1 0330-0059
				2 0330-0063
				3 0330-0064
				4 0330-0065
Series 3				3-108 2 0331-0049

Other sizes and types available.

CUTTING TIP ORDERING INFORMATION







Description	Illustration	Style/ Model	Size	Part Number	
Drag type. Clean metal. Plate cutting & trimming. Series 1		1-110	00	0330-0066	
			0	0330-0067	
			1	0330-0068	
			2	0330-0069	
			<hr/>		
Series 3		3-110	00	0331-0023	
			0	0331-0024	
			1	0331-0025	
			2	0331-0026	
			<hr/>		
Clean plate, straight line or circle. Machine cutting & trimming. (Series 1)		1-111	0	0330-0075	
			2	0330-0077	
			4	0330-0079	
			<hr/>		
Cutting close to bulkheads, hand cutting of river heads. machine cutting 45° with torch perpendicular. Series 1		1-112	00	0330-0083	
			0	0330-0084	
			1	0330-0085	
			2	0330-0086	
			3	0330-0087	
			4	0330-0088	
<hr/>					
Series 3		3-112	1	0330-0028	
			2	0330-0029	
			3	0330-0033	
			<hr/>		
Deseaming, gouging, removing defective welds, seams or excess (Series 1) metal, rivet washing and scarfing. (Series 3)		1-116	2	0330-0104	
			4	0330-0106	
			<hr/>		
			3-116	3	0330-0034
Deseaming, scarfing, gouging, weld preparation, removing defective welds, washing rivers. (Series 1) Series 3 Series 1		1-118	0	0330-0109	
			2	0330-0113	
			4	0330-0114	
			<hr/>		
			3-118	2	0330-0115
			<hr/>		
			1-118	6	0330-0116
			8	0330-0125	
10	0330-0126				
12	0330-0035				
<hr/>					
Underwater cutting with 3900C torch. General hand and scrap cutting rusty or painted surfaces. (Series 1)		1-129	2	0330-0135	
			4	0330-0137	
			<hr/>		

Ordering example: (Series 1) 1-1-101 (Series 3) 1-3-101

Other sizes and types available.

VICTOR® One Piece Liquid Air Fuel Gas, MAPP® & Propylene Cutting Tips

CUTTING TIP ORDERING INFORMATION

Description	Illustration	Style/Model	Size	Part Number		
General purpose hand and machine cutting Series 1		1-303MP	00	0330-0187		
			0	0330-0188		
			1	0330-0189		
			2	0330-0193		
			3	0330-0194		
			4	0330-0195		
			5	0330-0196		
Series 3		3-303MP	0	0331-0063		
			1	0331-0064		
			2	0331-0065		
			3	0331-0066		
					6	0330-0197
					8	0330-0510
					12	0330-0511
NOTE: Use large tip nut part no. 0309-0025 with HD series tips. (Series 1)						
Mill, foundry and scrap cutting, under severe or abusive conditions.		1-HDMP	6	0330-0510		
			8	0330-0511		
Cutting close to bulkheads, hand cutting of rivet heads, Machine cutting 35° with torch perpendicular. (Series 1)		1-312MP	2	0330-0331		
Scarfing, gouging, deseaming rivet cutting, removing defective metal or welds Series 1 Series 3		1-318MP	4	0330-0335		
			6	0330-0336		
			8	0330-0337		
			10	0330-0338		
		Series 3	3-318MP	2	0330-0371	
				4	0330-0372	
						

Two Piece Liquid Air Fuel Gas, MAPP® & Propylene Cutting Tips





CUTTING TIP ORDERING INFORMATION

Description	Illustration	Style/Model	Size	Part Number
General purpose hand and machine cutting torches. Series 1		1-GPM	000	0333-0220
			00	0333-0221
			0	0333-0222
			1	0333-0223
			2	0333-0224
			03	0333-0225
			4	0333-0226
			5	0333-0227
			6	0333-0228
			8	0333-0230
				

Two Piece Liquid Air Fuel Gas, MAPP® & Propylene Cutting Tips







CUTTING TIP ORDERING INFORMATION

Description	Illustration	Style/ Model	Size	Part Number
General purpose hand and machine cutting torches. Series 3		3-GPM	000	0333-0379
			00	0333-0380
			0	0333-0381
			1	0333-0382
			2	0333-0383
			3	0333-0384
			4	0333-0385
5	0333-0386			
High speed machine cutting thru 10"/252mm Series 1		1-MTHM	00	0333-0339
			0	0333-0340
			1	0333-0341
			2	0333-0342
			3	0333-0343
			4	0333-0344
5	0333-0345			
Heavy preheat for scrap, bevel & other heavy preheat requirements Series 1		1-HPM	1	0333-0243
			2	0333-0244
			3	0333-0245
			4	0333-0246
			5	0333-0247
			6	0333-0248
			8	0333-0250
10	0333-0251			
12	0333-0252			
High performance bevel cutting for use with MAPP & propylene gases. (Series 1)		1-BTMP	4	0333-0209
			5	0333-0210
			6	0333-0211

VICTOR® Two Piece MAPP® and Propylene Cutting Tips









CUTTING TIP ORDERING INFORMATION

Description	Illustration	Style/ Model	Size	Part Number
General purpose hand and machine cutting torches. Series 1		1-GPPM	000	0333-0260
			00	0333-0261
			0	0333-0262
			1	0333-0263
			2	0333-0264
			3	0333-0265
			4	0333-0266
			5	0333-0267
			6	0333-0268
	8	0333-0270		
Series 3		3-GPPM	000	0333-0388
			00	0333-0389
			0	0333-0390
			1	0333-0391
			2	0333-0392
			3	0333-0393
High speed machine cutting thru 10"/252mm Series 1		1-MTHP	00	0333-0352
			0	0333-0353
			1	0333-0354
			2	0333-0355
			3	0333-0356
			4	0333-0357
	5	0333-0358		
Heavy preheat for scrap, bevel & other heavy preheat requirements Series 1		1-HPPM	1	0333-0283
			2	0333-0284
			3	0333-0285
			4	0333-0286
			5	0333-0287
High performance bevel cutting for use with MAPP & propylene gases. (Series 1)		1-BTMP	4	0333-0209
			5	0333-0210
			6	0333-0211

One Piece Natural Gas & Propane Cutting Tips







VICTOR®

CUTTING TIP ORDERING INFORMATION

Description	Illustration	Style/ Model	Size	Part Number
General purpose hand and machine cutting. Series 1				1-200 0 0330-0143
				1 0330-0144
				2 0330-0145
				3 0330-0146
				4 0330-0147
				5 0330-0148
6 0330-0149				
General purpose extra length tips Series 1				1-200L 4 0330-0173
				6 0330-0201
Mill, foundry and scrap cutting under severe conditions. NOTE: Use large tip nut part no. 0309-0025 with HD series tips. Series 1				1-HDN 6 0330-0504
				8 0330-0505
				10 0330-0506
				12 0330-0507
				14 0330-0508
				1-HDN-H 6 0330-0544
Used for "blowing" rivets. Popular with various railroad applications. Series 1				1-207 2 0330-0164
				4 0330-0166
Scarfig, gouging, weld preparation, removing defective welds, washing rivets Series 1				1-234 2 0330-0344
Deseaming, gouging, weld preparation, removing defective welds, washing rivets Series 1				1-218 4 0330-0178
				6 0330-0179
				8 0330-0183
				10 0330-0184
Cutting close to bulkheads, rivet cutting, etc. Series 1				1-244 2 0330-0344
For applications requiring extra heavy pre-heat and wide kerf. Example: Demolition, ripping & RR car repair. 3/8"/9.75mm hose required minimum 80 PSIG oxygen and 15 PSIG fuel at torch. Series 1				1-MCN 6 0330-0543

VICTOR® Two Piece Natural Gas & Propane Cutting Tips

CUTTING TIP ORDERING INFORMATION

Description	Illustration	Style/ Model	Size	Part Number
General purpose hand and machine cutting torches. Series 1		1-GPN	000	0330-0300
			00	0330-0301
			0	0330-0302
			1	0330-0303
			2	0330-0304
			3	0330-0305
			4	0330-0306
			5	0330-0307
			6	0330-0308
7	0330-0309			
8	0330-0310			
Series 3		3-3-GPN	00	0333-0398
			0	0333-0399
			1	0333-0400
			2	0333-0401
			3	0333-0402
			4	0333-0403
High speed machine cutting thru 10"/252mm length tips Series 1		1-MTHN	00	0333-0363
			0	0333-0364
			1	0333-0365
			2	0333-0366
			3	0333-0367
			4	0333-0368
			5	0333-0369
			6	0333-0370
			8	0333-0372
Heavy preheat for scrap, bevel & other heavy preheat requirements. Series 1		1-HPN	1	0333-0323
			2	0333-0324
			3	0333-0325
			4	0333-0326
			5	0333-0327
			6	0333-0328
			8	0333-0330
			10	0333-0331
			12	0333-0332
			5	0333-0324
			internal w/ taper	
			6	0333-0325
			internal w/ taper	
			8	0333-0326
internal w/ taper				
High performance bevel cutting for use with mild steel HSLA, Ti & HY-80. Series 1		1-BTN	4	0333-0206
			5	0333-0207
			6	0333-0208
Rivet washing tip for use with natural gas. Series 1		1-RWTN	8	0333-0215
			10	0333-0213
A coarse splined scrap cutting tip for use with natural gas. Series 1		1-CSN	6	0333-0410
			8	0333-0411
			12	0333-0413

ACETYLENE HEATING TIPS ORDERING INFORMATION

Description	Illustration	Style/ Model	Size	Part Number
For preheating before welding, descaling paint burning, etc. Required pressures: 12/15 ACET.; 70/80 PSIG Oxy. NOTE: Size 8 is maximum size for use with cutting attachments (Series 1 / Series 3)		1-MFTA	6	0330-0527
			8	0330-0538
			10*	0330-0523
			12*	0330-0524
		3-MFTA	8	0331-0121

NATURAL GAS & PROPANE TIPS ORDERING INFORMATION

Description	Illustration	Style/ Model	Size	Part Number
For preheating, descaling, paint burning, etc. Required pressure: 15/30 PSI Fuel; 70/80 PSIG Oxy. NOTE: Not for use with cutting attachments (Series 1)		1-MFTN	10	0330-0521
			12*	0330-0522
		1-HTN	10	0333-0205

LIQUID AIR® FUEL GAS, MAPP® & PROPYLENE TIPS ORDERING INFORMATION

Description	Illustration	Style/ Model	Size	Part Number
General heating, preheating, descaling, etc. (Series 1)		1-HTMP	10	0333-0204

*Use 3/8"/9.75mm hose.

Reverse Flow Check Valves for Torches & Regulators



Check Valve - Pair Pak

ORDERING INFORMATION

Part Number	Description
0690-0012	CRO & CRF Regulator Pair Pack
0690-0035	CRF Regulator (Fuel) Check Valve
0690-0034	CRO Regulator (Fuel) Check Valve
0690-0011	CTO & CTF Torch Pair Pack
0690-0033	CTF Torch (Fuel) Check Valve
0650-0056	CTF-R Check Valve
0690-0032	CTO Torch (Oxy) Check Valve



Flame Buster Pair Pak

FlameBuster™ Flashback Arrestor

ORDERING INFORMATION

Part Number	Model/Description
0656-0009	FB-1E 3/8"/9mm BSP Torch Pair Pak
0656-0010	FB-1 Torch Pair Pak
0657-0011	FB-F Torch (Fuel) Flash Arrestor
0657-0015	FB-FR Regulator (Fuel) Flash Arrestor
0657-0010	FB-O Torch (Oxy) Flash Arrestor
0657-0014	FB-OR Regulator (Oxy) Flash Arrestor

FlameBuster™ Flashback Arrestor with Kwik-Connect Couplings for Torches & Regulators

ORDERING INFORMATION



FlameBuster Plus™

Part Number	Model/Description
0656-0002	FBP-1 Flame Buster Plus Torch Plain Pak w/ Kwik Connect
0657-0009	FBP-CF Flame Buster Plus Torch (Fuel)
0657-0008	FBP-CO Flame Buster Plus Torch (Oxygen)
0657-0003	FBP-F Flame Buster Plus
0657-0002	FBP-O Flame Buster Plus
0656-0010	FBR-1E Flame Buster 3/8"/9mm BSP Reg. Plain Pak
0656-0004	FBR-1 Flame Buster Reg. Plain Pak
0656-0011	— Flame Buster Packaged Pair



Kwik-Connect

Kwik-Connect™ Torch/Hose Connections

ORDERING INFORMATION

Part Number	Model/Description
0656-0000	KC-1 Kwik Connect Torch Plain Pak



Replacement Cartridge

Vanguard Flashback Arrestor Replacement Cartridge

ORDERING INFORMATION

Part Number	Model/Description
0657-0036	Vanguard Torch Handle Replacement Cartridge (315FC, 315EFC, 100FC, 100EFC) (Both Gases)
0657-0016	Vanguard Cutting Torch Replacement Cartridge (ST2600FC, ST1000FC, ST900FC) (Oxygen 9/16" RH)
0657-0017	Vanguard Cutting Torch Replacement Cartridge (ST2600FC, ST1000FC, ST900FC) (Fuel 9/16" LH)
0657-0023	Vanguard Cutting Torch Replacement Cartridge (ST2600EFC, ST900EFC) (Fuel BS-3 3/8" LH)
0657-0022	Vanguard Cutting Torch Replacement Cartridge (ST2600EFC, ST900EFC) (Oxygen BS-3 3/8" RH)

Note: Flashback arrestor replacement cartridges include an "O" Ring but do not include a replacement reverse flow check valve. (9/16" pair #0690-0027) (BS-3 pair #0690-0028)